

1486—84

Square-head step-point with sphere set screws.
Product grades A and B. Construction and dimensions

MKC 21.060.10
12 8400

01.01.86

- 1.
- 8 20
- 2.

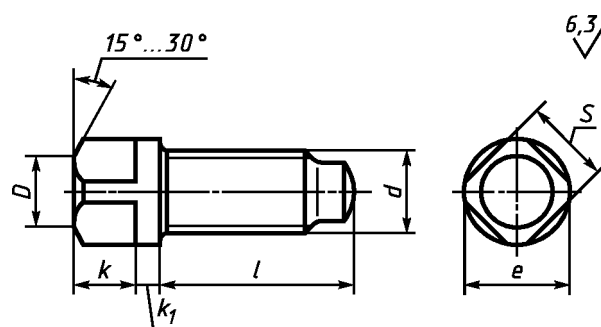

Вариант исполнения

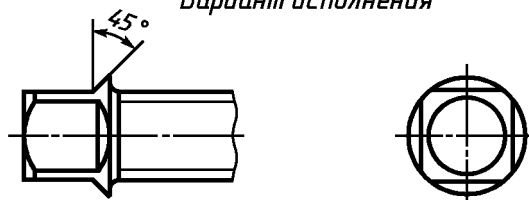

$$D = (0,90 \div 0,95)S$$

	<i>d</i>	8	10	12	16	20
	<i>S</i>	8	10	12	17	22
		7	8	10	14	18
		10	13	16	22	28
		2	3	3	4	5
X CQ tf	14		—	—	—	—
	16			—	—	—
	20				1	—
	25					—
	30					—
	35					—
	40					
	45	—				
	50	—				
	55	—	—			
	60	—	—			
	65	—	—	—		
	70	—	—	—		
	75	—	—	—		
	80	—	—	—		
	90	—	—	—	—	
100	—	—	—	—		

$d = 10$, 6g, $l = 25$, 14 , :

B.M10-6g-25.14 1486-84

45 , 40 -

. *10-6 g-25.45H.40X.05* 1486-84

59—1, :

A.M10-6g-25.32 1486-84

1, 2. (

3. — 24705, — 1).

10549.

4. — 24670.

5. — 12414.

1000 . ,

l,	d,				
	8	10	12	16	20
14	8,57	—	—	—	—
16	9,19	15,76	—	—	—
20	10,46	17,89	27,82	—	—
25	12,06	19,97	31,53	70,76	—
30	13,73	22,49	35,15	77,28	—
35	15,30	25,00	38,76	83,84	—
40	15,90	27,52	42,46	90,58	166,22
45	—	30,07	46,09	97,15	176,72
50	—	32,55	49,69	103,85	187,12
55	—	—	53,39	110,55	197,62
60	—	—	57,01	117,05	208,02
65	—	—	—	123,95	218,42
70	—	—	—	130,55	228,82
75	—	—	—	137,15	239,22
80	—	—	—	143,85	249,72
90	—	—	—	—	270,52
100	—	—	—	—	291,32

0,97— , 1,08— : 0,356 —
 .(, . 1).

1.

-

. . . , . . . , . . . , . . .

2.

08.05.84 1590

3.

1486-84

4.

-

1759.0-87	10
1759.1-82	6, 8
1759.2-82	7, 8
1759.4-87	8
10549-80	3
12414-94	5
24670-81	4
24705-2004	3
25556-82	8

5.

1,

1987 . (12—87)

1486—84

(. . « . »)

ore		
.	1486—S4	1486-75

(1 2008 .)